

# Water carried heating

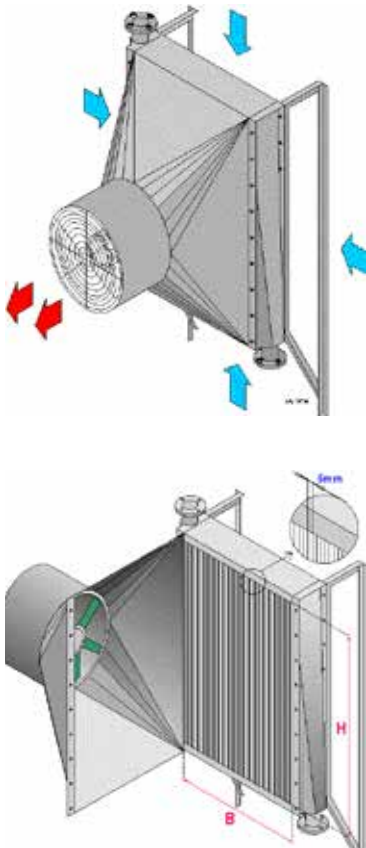

The DACS all steel, galvanized-radiator produces plenty of dry, hot air without any risk of sparks flowing. The heating surface and the assembly rack on the radiator are fully hot dipped galvanized and thus protected against the aggressive environment in a poultry house.

### Lasting capacity

It is important, especially during the winter months, to have full heating capacity available. To keep the radiator capacity at optimum rates it is essential that cleaning is easy and efficient, as dust will block the air channels and lead to inefficient and slow heating of the building.

### High pressure water cleaning

The DACS radiator, with its 1mm material thickness on all heating segments will stand cleaning by high pressure water cleaning without bending. The swing-away front panel and a 5mm spacing between the segments allow for easy access and thorough cleaning. All segments are vertically oriented to ensure complete drainage after washing.

### Efficient heat distribution

Each radiator is equipped with a 0.3 kW blower. The system is typically placed on the building end 2.5-3 meters from the side wall. This placement gives the most efficient and even heat distribution. When mounted on our standard frame, the radiator sits 40 cm from the wall. A sturdy, galvanized frame mounts directly to the wall and holds the radiator in place.

The frame has been designed to distribute the weight of the radiator to the floor, making installation in almost any type building possible. The system is dimensioned with a very easy water flow inside the heating element which means that only a small circulation pump is needed. This minimizes the energy consumption of the radiator. The performance on the radiator is stated at a room temperature of 32°C and an average temperature in the radiator of 85°C. The performance of the radiator raises the bigger the difference on the systems incoming water and room temperature is.

### Several sizes

The radiators are available in several different sizes. Consult DACS for proper size selection.

## TECHNICAL SPECIFICATIONS

TYPE	Measurement (HxW) mm	Weight kg	Area m2	Content litres	Flow l/min	Pressure Bar	Output kcal/h	kW
VF-36	750 x 1250	285	58.5	20.5	108	0.2	57,750	67.1
VF-56	1250 x 1250	443	97.5	34	180	0.2	76,650	89.0

